

Tracheostomy Tube Adult Home Care Guide

How The Tracheostomy Works	2
What Changes Occur	
Safety Tips	3
Getting Ready To Go Home	4
Things You Will Need	
Tips For Daily Living	5
Humidification, Bathing, Illness, Clothing, Getting Out	
What You Will Need In A Travel Kit	
Suctioning	6
What You Will Need	
How To Suction	
Changing Ties	8
What You Will Need	
How To Change Twill Tape Ties	
Skin Care	9
What You Will Need	
How To Clean Around The Opening	
Changing the Tube	10
What You Will Need	
How To Change A Cuffed Tube	
How To Change A Cuffless Tube	
Inner Cannula Care	14
What You Will Need	
Reusable Inner Cannula Care (CFN, CFS, FEN, LGT, LPC)	
Replacing A Disposable Inner Cannula (DCFN, DCFS, DCT, DFEN, PERC)	
Tracheostomy Tube Cleaning Reference Guide	16
Solving Problems	17
Product Description: FEN & LPC	20
Product Descriptions: CFN, CFS & LGT	21
Product Descriptions: DCT, DFEN & PERC	22
Product Descriptions: DCFN & DCFS	23
Product Description: SCT	24
Speaking Valve	25
Glossary (in Plain English)	28
More Help	30

How The Tracheostomy Works

The most common reasons for performing a tracheostomy are to bypass an upper airway obstruction or to provide long-term mechanical ventilator support. The doctor makes an opening (stoma) in the front of the neck into the windpipe (trachea). Then a curved plastic tube (tracheostomy tube) is placed into the opening through which you breathe.

What Changes Occur

While your tube is a wonderful aid to help you breathe better, it requires care and some changes in the way you do things. When you breathe through your nose and mouth, the air is filtered, warmed and moistened before it gets to your lungs. With a tracheostomy tube, air goes directly into your windpipe and to your lungs without being filtered, warmed or moistened. You will learn how to make up for this by using the proper equipment and by learning proper tracheostomy tube care.

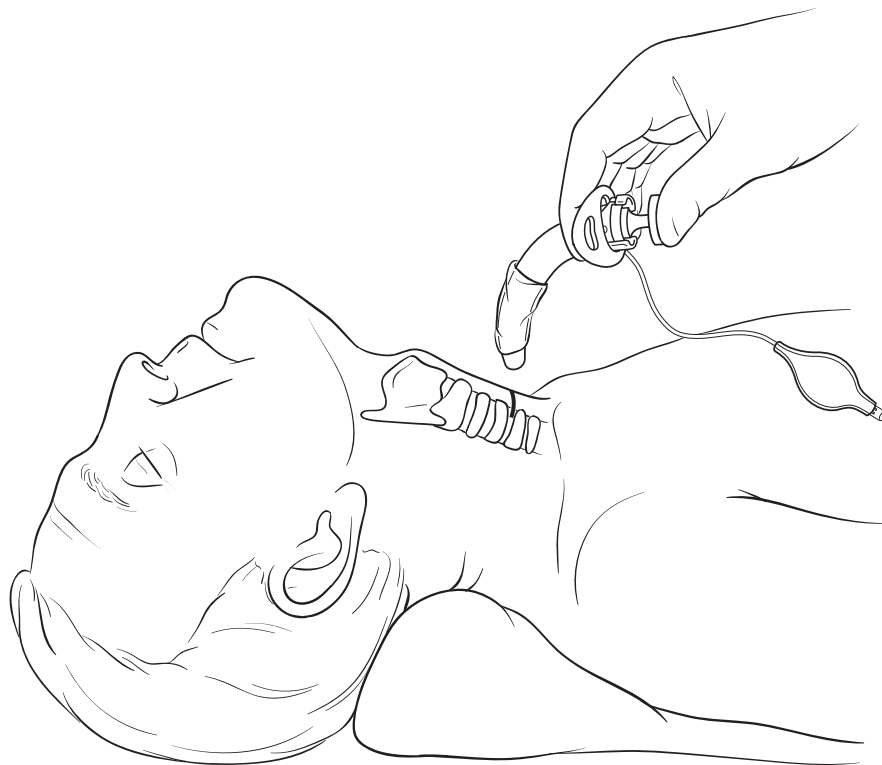
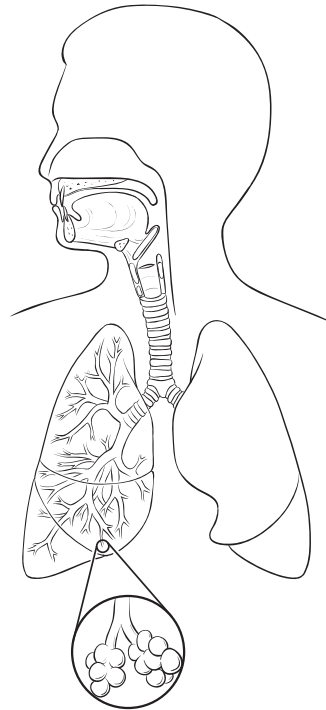

Safety Tips

Follow your doctor's or hospital's directions for care. If instructions in this guide are different from your training, follow your training.

Review with your physician and/or home healthcare provider the various features and accessories for your Shiley® Tracheostomy Tube. Carefully read the *Instructions For Use* pamphlet included in each carton.

Only people who have been trained by a healthcare professional should perform tracheostomy care.

Always have extra tracheostomy tubes on hand for an emergency (one the same size and one smaller).

Do not re-sterilize Shiley® Tracheostomy Tubes or attempt to clean them in boiling water. They are designed for "Single Use Only."

Don't place the plastic tracheostomy tube anywhere the temperature is over 120° F.

If you have a cuffed tracheostomy tube, avoid over-inflating the cuff. This can injure your windpipe. It may also cause the cuff to extend past the end of the tube where it can restrict or block air flow.

Watch for these signs of infection. If present, notify your physician:

- Red, inflamed skin at stoma
- Foul-smelling mucus
- Bright red blood in mucus

If you are unable to remove your tracheostomy tube, or if you are unable to remove the inner cannula, do not force it. Call your physician.

Avoid dust and mold.

Avoid tobacco and other kinds of smoke.

Keep clothing away from the tracheostomy tube except for a protective scarf.

Be sure all caregivers know CPR for tracheostomy patients.

Post CPR instructions where they will be handy in an emergency.

Post emergency numbers near the phone.

Avoid fumes from cleaning solutions such as ammonia or bleach.

Be careful using any kind of spray product, such as hairspray, furniture polish, etc. You do not want to inhale the mist.

If You Use A Ventilator

Routinely check the ventilator safety and auditory alarms to be sure they are working properly.

Be sure the ventilator tubes are properly placed so that they don't pull on the tracheostomy tube.

Don't twist or pull on the tracheostomy connector any more than you must. This may cause discomfort or disconnect the ventilator tubes.

Hold the tracheostomy tube in place when connecting or disconnecting the ventilator or humidification tubing.

When using a ventilator with a fenestrated tracheostomy tube, always use a non-fenestrated inner cannula with a 15 mm connector.

Getting Ready To Go Home

Your tracheostomy tube gives you the freedom to leave the hospital and resume your life at home. However, it will require regular care to ensure that it works properly. That is why you will receive training in the hospital.

Ask plenty of questions and take notes during your hospital training sessions. Make sure you understand the proper methods of tracheostomy tube care. Practice every chance you get under the guidance of your instructor. The more practice you have, the more confident and capable you will be once you go home.

Have family members or a friend attend the instruction at the hospital so that they can help you if needed. It is always good to have someone you can turn to for help if you are sick or there is an emergency.

Your doctor, nurse or therapist is your best source for advice. This guide will provide helpful tips and reminders so that things go smoothly once you are home again.



What You Will Need

- Blunt-nose bandage scissors
- Box of facial tissues
- Container (*for catheter rinse water*)
- Cotton swabs
- Gloves (*like your doctor uses*)
- Hydrogen peroxide
- Syringe (*if you have a cuffed tube*)
- Pre-cut tracheostomy dressing
- Replacement tracheostomy tubes (*one the same size and one smaller*)
- Small wash basin
- Sterile 4" X 4" gauze pads
- Sterile normal saline or sterile water (*to soften mucus so that it may be suctioned*)
- Suction catheter
- Suction machine with connecting tubing
- Tracheostomy tube mask (*optional*)
- Twill tape or other tracheostomy tube holder (*to secure the tube in place*)
- Water-soluble lubricant (*KY Jelly or similar*)

NOTE: Some items come from your home healthcare supplier, some you must buy at the store.

Tips For Daily Living

Humidification

Normally, your nose and mouth would moisten the air you breathe to protect the lining of your lungs. With a tracheostomy tube, you have to moisten the air another way. That's why it is important to drink plenty of liquids and use a humidifier or an "artificial nose."

Bathing

While a little moisture is good, too much can cause problems. So when you shower, direct the shower spray at chest level and place a shower shield or protective covering over your tracheostomy tube. Be careful to keep soap and water away from the tube and stoma when washing your face. Also, take care to cover your tracheostomy tube when you are shaving or using powders, hair spray, etc. around your face and neck.

Illness

For tracheostomy patients, an ounce of prevention is definitely worth a pound of cure. Eat a healthy diet. Get plenty of rest. Avoid contact with people with colds.

If illness occurs, you may need to suction more frequently. Be sure to get plenty of fluids, particularly if you have symptoms of fever, vomiting or diarrhea. If you vomit, cover the tracheostomy tube with an artificial nose or towel to keep vomit out of your airway. If you think vomit may have entered the tracheostomy tube, suction immediately.

Clothing

The main concern about clothing is that it does not block the tracheostomy tube. Avoid

crew necks and turtle necks in favor of v-necks and open collar shirts or blouses. Also, do not wear clothes that shed fibers or lint.

Getting Out

If your doctor says you can leave home to go shopping or visit friends, do it. It is a wonderful break from the routine, and it will lift your spirits. Just take along a travel kit. (See below.)

If it's very cold outside, be sure to wear an artificial nose or loosely cover the tracheostomy tube with a scarf, kerchief or gauze. This helps to warm the air as you breathe, so that the cold air doesn't irritate your windpipe and lungs. It also helps keep out dust or dirt on windy days.



What You Will Need In A Travel Kit

- Blunt-nose scissors
- Breathing medications (*if you use them*)
- Manual resuscitation bag (*if ordered by doctor*)
- Normal saline
- Portable suctioning device
- Spare tracheostomy tubes with obturator and ties (*one the same size and one smaller*)
- Suction catheter
- Tissues

NOTE: *Appropriate humidification, when indicated, helps ensure that the cannula and fenestration remain open and function properly.*

Suctioning

The lungs and windpipe naturally produce mucus. The mucus cleans the air as we breathe by trapping small particles. It then moves up the windpipe until it can be swallowed.

With a tracheostomy, mucus can collect in and around the tracheostomy tube. It must be removed so it doesn't dry and block the tube. How frequently you suction will be determined by need based on the amount of your secretions and by your doctor or home healthcare provider.



What You Will Need

- Collection jar for secretions
- Container for water
- Gloves
- Sterile water or saline
- Suction catheter
- Suction machine

Read Before Suctioning

NOTE: *Always follow your doctor's or hospital's directions if they differ from the directions in this guide. Carefully review with your physician or home healthcare provider the applicable clinical guidelines to determine the appropriate size suction catheter for your tube. The following table can be used as a guide to help select the suction catheter size based on the internal diameter of the tube.*

<u>Tracheostomy Tube Internal Diameter</u>	<u>Suction Catheter</u>
5.0 mm	10 Fr.
5.5 mm	10 Fr.
6.0 mm	10 Fr.
6.5 mm	12 Fr.
7.0 mm	14 Fr.
8.0 mm	14 Fr.
9.0 mm	14 Fr.

NOTE: *Before suctioning a fenestrated tube, make sure the non-fenestrated inner cannula is in place.*

NOTE: *If you require removal of pooled secretions above the cuff, follow the instructions of your physician or home healthcare provider.*

How To Suction

The following procedure is to be used only if your physician instructs you to do it.

1. Wash hands.
2. Put on gloves.
3. Attach suction catheter to suction machine.
4. Rinse catheter by suctioning sterile water.
5. Hyperoxygenate by taking 3-4 deep breaths.
6. With your thumb off the thumb hole, gently insert the catheter into the tracheostomy tube until it reaches the end of the tube or until you cough.



7. Cover the thumb hole on the catheter to suction.



8. Slowly remove the catheter while rolling it between your thumb and forefinger.

Also pulse the suctioning by covering and uncovering the thumb hole of the catheter. (Start to finish should take no longer than 10 seconds.)

9. If you need to suction again, rinse the catheter first and take another 3-4 deep breaths, then repeat the suctioning stage. (Allow enough time between each catheter insertion for normal breathing or ventilator support to reoxygenate your body.)



10. Look at the mucus you have suctioned.

Normal: Clear, with no odor.

Infection: Yellow or green color with foul-smelling odor.

Blood: A few streaks of blood is OK. But if it has more bright red or old dark blood, there could be a problem.

11. If you see signs of infection or bright red blood, call your doctor.

Read Before Suctioning

NOTE: Follow the hospital's or home healthcare provider's instructions for storage, use and disposal of suction catheters. Also, keep the suction machine, tubing and collection jar clean according to the home healthcare provider's instructions.

NOTE: It is common to see suctioning using a sterile technique in hospitals. In the home setting, a clean technique may be used. Discuss this with your home healthcare provider.

Changing Ties

It is important to keep the area around the opening in the neck clean to help prevent infection. So, change ties daily or whenever they become wet or soiled.



What You Will Need

Blunt-nose scissors
Gloves
Twill tape or Shiley® Tracheostomy Tube Holder

How To Change Twill Tape Ties

1. Wash hands. (If you have an assistant, they must wash their hands, too.)
2. Leave old ties in place. Pull one end of the twill tie through either neck flange hole. Adjust the ends of the tie until one is 3-4 inches longer than the other.



3. Bring both ends of the tie around your neck and insert the longer end of the tie through the other neck flange hole.



4. Pull the tie snug. Place one finger between the tie and the neck and tie the two ends together using a square knot. Do not use a bow.



5. Cut the ends of the ties leaving only 1 or 2 inches.
6. Carefully cut and remove soiled ties.

Read Before Changing Ties

CAUTION: If you use a cuffed tube, protect the inflation line when cutting the ties.

NOTE: Change the location of the knot to prevent skin irritation.

Skin Care

Skin care is easy, but very important. It should be done at least twice a day: once in the morning and once at night. If you smell an odor around the neck or opening, clean the area every 8 hours until the odor is gone.



What You Will Need

- Cotton swabs
- Hydrogen peroxide and sterile water (mixed in equal parts)
- Pre-cut tracheostomy dressing, if required
- Sterile gauze pads

How To Clean Around The Opening

1. Wash your hands.
2. Dip a cotton swab into the hydrogen peroxide and water mixture.
3. Roll the cotton swab between the tracheostomy tube and the skin around the opening. Clean from the stoma outward. This removes wet or dried mucus.



4. Repeat steps 2 and 3 using a fresh cotton swab each time, until entire area around the opening is clean.
5. Rinse the area using clean cotton swabs dipped in clean water only.
6. Use a dry gauze pad to pat lightly around the opening.
7. Replace the tracheostomy dressing, if required.

Read Before Cleaning Around The Opening

CAUTION: Watch for red, irritated areas. If excessive redness or pimples occur around the opening, call your doctor, reduce humidity delivered around opening and use only sterile water for cleaning. **Do not use** over-the-counter, petroleum-based creams like zinc oxide or Vaseline around the opening. If your doctor prescribes an ointment, apply it according to his instructions.

Changing The Tube

Changing your tracheostomy tube at the recommended intervals helps to ensure your tube's proper operation. Shiley® Tracheostomy Tubes should not be used more than 29 days and should be replaced and discarded per your home healthcare provider's instructions.



What You Will Need

- Blunt-nose scissors
- Gloves
- Pre-cut tracheostomy dressing
- Replacement tracheostomy tube
- Small wash basin
- Sterile 4" X 4" gauze
- 10 cc syringe (for cuffed tubes)
- Twill tape or Shiley® Tracheostomy Tube Holder
- Water-based lubricant

How To Change A Cuffed Tube

1. Wash hands. Put on gloves.
2. Take the replacement tracheostomy tube out of its container. Take care to avoid damaging the cuff, inflation line or pilot balloon. Remove the inner cannula, if it is in place.
3. Use a clean, dry syringe to inflate the cuff to the proper leak test volume. The markings on the syringe show air volume. *The following are test volumes only.* Your doctor will tell you the appropriate inflation volume to use when the tube is in your trachea.



Shiley® Tube Size	Leak Test Volume
10	20 cc
8	17 cc
6	14 cc
4	11 cc

Read Before Changing Any Tube

CAUTION: Frequent and routine changes of the tracheostomy tube are recommended. Shiley® Tracheostomy Tubes should not be used more than 29 days and should be replaced and discarded per your home healthcare provider's instructions.

NOTE: Always follow your doctor's or hospital's directions, if they differ from the directions in this guide. Do not attempt to change your tracheostomy tube unless you have been trained to do so. Contact your doctor or hospital with any questions you may have.

NOTE: Always keep complete, sterile replacement tracheostomy tubes handy (one the same size and one smaller) in case of an emergency.

NOTE: Shiley® Tracheostomy Tubes are designed for single-patient use only and cannot be resterilized by any method.

CAUTION: Carefully read and understand the "Instructions For Use" packaged with each tracheostomy tube before using it.

4. Place the entire tube, including inflation line, in a small wash basin with enough sterile water to cover it, and watch for bubbles indicating an air leak.



5. Deflate the cuff completely using a syringe. As you are doing this, gently push the cuff away from the end of the tube. Be sure to remove all air. (This makes it easier to insert the tube.)

6. Insert the ties through one neck flange hole. Insert the obturator into the cannula. (Do this before inserting the tube.)



7. Lubricate the tube using a thin layer of water-based lubricant such as KY Jelly.



8. Place the tube on a sterile surface.

9. If required, suction secretions that might have pooled above the cuff of the old tube. Follow your doctor's or hospital's directions for this procedure.

10. Deflate the cuff completely using the syringe, cut the ties and remove the old tube.



11. As you breathe in, gently insert the new tube, pushing back, then down in an arcing motion.

12. Immediately remove the obturator, while holding the tube in place with your fingers.



Read Before Changing A Cuffed Tube

NOTE: During the leak test, if you see any air leaks, do not use the tube.

CAUTION: Carefully air dry the inflation line before inflating to ensure no water enters when you inflate the cuff.

CAUTION: Do not use anything sharp while handling the cuff to avoid causing damage to it.

NOTE: Do not use petroleum-based products, such as Vaseline to lubricate your tube.

NOTE: If you have a fenestrated tube, insert the inner cannula before inflating the cuff.

NOTE: If you use a fenestrated tube, make sure the cuff is fully deflated prior to using a decannulation plug.



13. Insert the new inner cannula making sure that it is properly secured in place. If you use a twist-lock inner cannula, it is secure when you feel it lock into place and the blue dots on the inner and outer cannulae are lined up. If you are using a disposable inner cannula, make sure that both sides of the winged flange are snap-locked securely in place.



14. Inflate the cuff to the proper volume using a syringe. (Your doctor will tell you what volume to use.)

15. Finish fastening the ties as described on page 8.

16. Throw away the old tube.

How To Change A Cuffless Tube

1. Wash hands. Put on gloves.



2. Insert the ties through one neck flange hole. Insert the obturator into the cannula. (Do this before inserting the tube.)



3. Lubricate the tube using a thin layer of water-based lubricant such as KY Jelly.

4. Place the tube on a sterile surface.

5. If required, suction secretions.

6. Cut the ties and remove the old tube. If you are unable to remove it, call your doctor. Do not force it.

Read Before Changing Your Tube

NOTE: You probably won't have trouble inserting the new tube. But, if you do, be sure your head is tilted back as you insert the tube. If you are still having difficulty, spread the skin around the stoma and insert the tube as you are breathing in or use a fresh tube that is a size smaller. Call your doctor immediately, if you have any problems.



7. As you breathe in, gently insert the new tube, pushing back, then down in an arcing motion.



8. Immediately remove the obturator, while holding the tube in place with your fingers.

9. Insert the new inner cannula making sure that it is properly secured in place.



10. If you use a twist-lock inner cannula, it is secure when you feel it lock into place and the blue dots on the inner and outer cannulae are lined up. If you are using a disposable inner cannula, make sure that both sides of the winged flange are snap-locked securely in place.



11. Finish fastening the ties as described on page 8.

12. Throw away the old tube.

Inner Cannula Care

Reusable Inner Cannula Care (CFN, CFS, FEN, LGT, LPC)

1. Wash your hands.
2. Hold the neck flange steady with one hand.
3. With the other hand, grasp the twist-lock inner cannula connector and carefully unlock it using a counterclockwise motion.

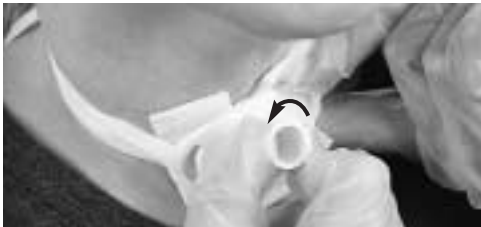

4. Pull the inner cannula out of the tube, using a downward motion.

5. If you need to use a ventilator during this cleaning procedure, insert a clean spare inner cannula (SIC) which is designed for short-term use and has a red 15 mm connector.



What You Will Need

- Gloves
- Hydrogen peroxide
- Hydrogen peroxide and sterile water (mixed in equal parts)
- Small non-abrasive brush or pipe cleaners
- Small wash basin
- Spare inner cannula (SIC) if using a reusable inner cannula tube and you are using a ventilator
- Sterile 4" x 4" gauze

6. Place the soiled inner cannula in a small wash basin containing sterile normal saline, distilled water, a solution of water and a mild detergent or a solution of half hydrogen peroxide and half water. Use a small, non-abrasive brush or pipe cleaner to gently remove mucus.

Read Before Inner Cannula Care

NOTE: *Cleaning procedure should be clearly understood before proceeding. Follow your physician's recommendations for cleaning procedure and schedule. The above procedure is to be used only if your physician instructs you to.*

NOTE: *The SIC **should not be used** as a replacement for the inner cannula provided with your tracheostomy tube.*

NOTE: *To loosen dried-on mucus, use a mixture of equal parts of hydrogen peroxide and distilled water. Pour this mixture through the inner cannula. **DO NOT SOAK.** Rinse the inner cannula thoroughly with sterile normal saline or distilled water to remove all hydrogen peroxide.*

CAUTION: *Do not use cleaning agents such as alcohol, glutaraldehyde or bleach. They will damage the inner cannula.*

7. After cleaning, rinse the inner cannula thoroughly with sterile normal saline or distilled water to remove all hydrogen peroxide.
8. Air dry the inner cannula by gently shaking it.
9. Hold the neck flange steady with one hand.
10. Remove the spare inner cannula, if you used one.



11. Reinsert the clean twist-lock inner cannula into the tube and secure it by gently twisting it clockwise until the blue dot on the inner cannula lines up with the blue dot on the tube.



12. Clean the spare inner cannula, air dry and store in a safe place.

Replacing A Disposable Inner Cannula (DCFN, DCFS, DCT, DFEN, PERC)

The Disposable Inner Cannula (DIC) system eliminates the need to clean the inner cannula. The snap-lock feature provides a secure connection and makes it easy to insert and remove the DIC with little or no discomfort.

1. Wash your hands.
2. Hold the neck flange steady with one hand.
3. With the other hand, gently squeeze the snap-lock and pull the inner cannula out of the tube, using a downward motion.



4. Throw away the used inner cannula.
5. Gently squeeze the snap-lock of the new inner cannula and insert it into the tube. Release the snap-lock connector when it securely locks onto both sides of the connector rim.

Read Before Inner Cannula Care

NOTE: When inserting a reusable inner cannula, be sure the twist-lock connector is secure. It is locked only when the two blue dots on the 15 mm connector of the inner cannula and the outer cannula are lined up. If it becomes worn or loose, report this to your home healthcare provider for prompt replacement.

CAUTION: A Shiley® Disposable Inner Cannula (DIC) should never be cleaned and reused. It is designed for one-time use only.

NOTE: The DIC should be changed and discarded according to the schedule your doctor or home healthcare provider gives you.

Tracheostomy Tube Cleaning Reference Guide

Name of Part	Hydrogen Peroxide & Water 1/2 & 1/2	Normal Saline or Distilled Water	Water & Mild Detergent	Alcohol	Boiling In Water	Autoclave ETO/ Gamma	Betadine
Inner cannula	*Yes	Yes	*Yes	No	No	No	No
Disposable inner cannula	No	No	No	No	No	No	No
Outer cannula (cuffless)	*Yes	Yes	*Yes	No	No	No	No
Outer cannula (cuffed)	No	Yes	No	No	No	No	No
DGP	*Yes	Yes	*Yes	No	No	No	No
DDCP	No	No	No	No	No	No	No
Obturator	*Yes	Yes	*Yes	No	No	No	No

* Do not immerse in hydrogen peroxide more than a few minutes. Rinse thoroughly to remove all residual hydrogen peroxide, detergent or any other solution.

Read Before Cleaning Your Tube

CAUTION: Shiley® Tracheostomy Tubes are designed for single-patient use only and can not be re-sterilized by any method including soaking and/or rinsing them in boiling water.

NOTE: Do not expose Shiley® Tracheostomy Tubes to temperatures above 120° F.

NOTE: Do not expose Shiley® Tracheostomy Tubes to any chemical agents, other than those listed above, because they may degrade the plastic (polyvinyl chloride). This will result in tube damage.

NOTE: Detergents with artificial colors, degreasers, sterilizing/anti-bacterial ingredients may discolor the tracheostomy tube. They may also degrade the plastic (polyvinyl chloride) resulting in tube damage.

CAUTION: A Shiley® Disposable Inner Cannula (DIC) should never be cleaned and reused. It is designed for one-time use only.

Solving Problems

Symptom	What May Have Happened	What To Do
Excessive air leak through nose and mouth.	Insufficient air in cuff. (Cuffed tubes only)	Deflate and re-inflate the cuff with the proper amount of air.
	Leak in cuff, inflation line, pilot balloon or luer valve. (Cuffed tubes only)	Replace the tube.
	Tube too small for trachea.	Call your doctor.
	You may have an uncuffed tube and need a cuffed tube.	Call your doctor.
	Fenestrated inner cannula is in the tube.	Remove it and replace it with a non-fenestrated inner cannula.
Tube comes out of the opening in the neck.	Excessive pulling or weight at the connector.	Hold the neck flange with one hand while disconnecting the ventilator tube. Readjust ventilator tubing to reduce pulling. Move the ventilator if need be. Reattach the ventilator tube to the trach tube connector.
	Trach tube ties too loose or incorrectly tied.	Retie the trach ties. (See page 8)
Difficult to remove or insert inner cannula for fenestrated tube.	Tracheal lining may be pushing through the fenestration.	Call your doctor.
	Trach tube alignment has changed.	Call your doctor.

Symptom	What May Have Happened	What To Do
<p>Tube, or any part of the tube, breaks or doesn't work.</p>	<p>Excessive use or wear on the trach tube.</p>	<p>Replace the tube.</p>
	<p>Trach tube was cleaned using improper cleaning agents.</p>	<p>Replace the tube. Always use only those cleaning agents recommended by the tube manufacturer. (See page 16)</p>
	<p>Excessive pulling or weight at the connector.</p>	<p>Hold the neck flange with one hand while readjusting ventilator tubing to reduce pulling. Move the ventilator if need be. Put the ventilator tube adapter back onto the trach tube connector.</p>
	<p>Trach tube ties are too loose or incorrectly tied.</p>	<p>Make sure tube is properly inserted in the trachea. Then retie trach ties. (See page 8)</p>
<p>Unable or difficult to pass a suction catheter through trach tube.</p>	<p>Mucus is plugging the trach tube.</p>	<p>Remove inner cannula and clean it, if reusable. Replace it, if disposable (DIC).</p>
	<p>Catheter is too large for the tube size.</p>	<p>Contact your home healthcare provider for guidance in the size of catheter needed.</p>
	<p>Tube is not properly positioned in the trachea.</p>	<p>Reposition the tube.</p>
	<p>A fenestrated inner cannula is in the tube.</p>	<p>Replace it with a non-fenestrated inner cannula.</p>

Symptom	What May Have Happened	What To Do
Ventilator's "High Pressure" alarm goes off.	Ventilator tubing is blocked or kinked.	Clear tubing of kink or block.
	Mucus is plugging the trach tube.	Suction to clear mucus.
	Excessive amounts of water have collected in the ventilator circuit, blocking airflow.	Drain the ventilator circuit of water or condensation.
	If the first three suggestions don't work, there may be a more serious problem.	Contact your home healthcare provider immediately.
Ventilator's "Low Pressure" alarm goes off.	Ventilator tubing is not connected at machine.	Make sure all tubing to the machine and patient is connected.
	If you have a cuffed trach tube: there may be a leak in the cuff, inflation line, pilot balloon or luer valve.	Remove the ventilator tubing from the trach tube. Deflate and re-inflate the cuff with the proper volume. Replace the tube if it does not remain inflated. Attach ventilator tubing. Turn on the machine. If the problem continues, replace the tube.
	A fenestrated inner cannula is in the tube.	Replace it with a non-fenestrated inner cannula.
	If the first three suggestions don't work, there may be a ventilator problem.	Contact your home healthcare provider. Deliver breaths with a manual resuscitation bag, if available.

Product Descriptions

FEN & LPC

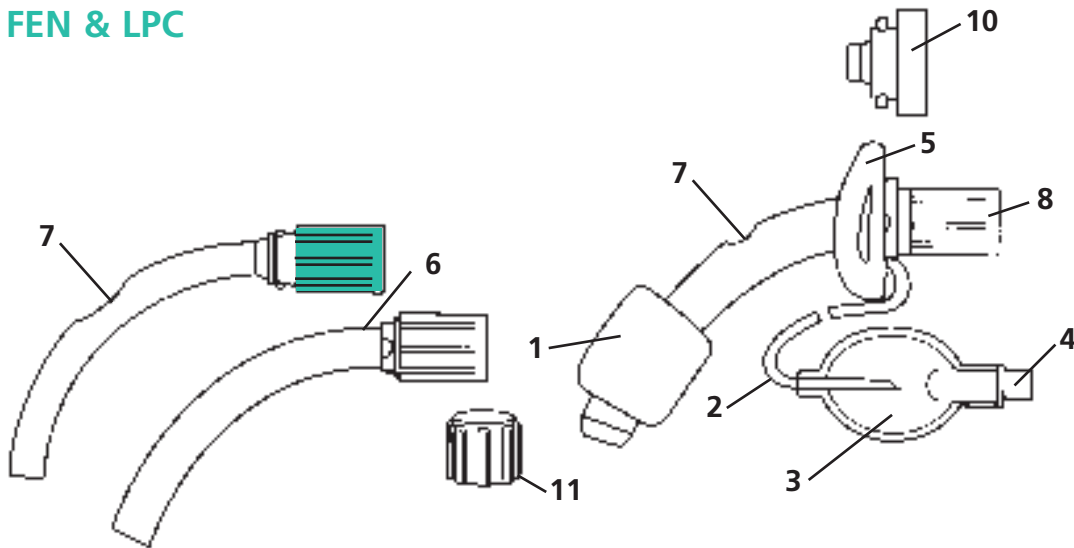

1. Cuff (FEN, LPC)

The "balloon" on the end of the trach tube. When inflated, it forms a seal against the wall of your windpipe. This stops the air flow through your mouth and nose so that you breathe through the trach tube.

2. Inflation Line (FEN, LPC)

Thin plastic tubing that carries air to and from the cuff.

3. Pilot Balloon (FEN, LPC)

Small plastic balloon-like component on the end of the inflation line. Indicates if air is in the cuff.

4. Luer Valve (FEN, LPC)

Where the syringe is connected to inflate or deflate the cuff.

5. Soft Swivel Neck Flange

Contains product designation and size information. Twill ties or Shiley® Tracheostomy Tube Holders attach through the holes on either side securing the tube to your neck. Soft swivel design helps to position the tube properly and comfortably.

6. Reusable Inner Cannula

The tube that fits inside your trach tube. This can be easily detached and cleaned to remove mucus. FEN and CFN have a fenestrated inner cannula.

7. Fenestration (FEN & CFN)

A hole on the curved part of the trach tube or inner cannula. When a fenestrated inner cannula is used or the non-fenestrated inner cannula is removed, it allows air to flow through the vocal cords, mouth and nose so you can speak.

Product Descriptions

CFN, CFS & LGT

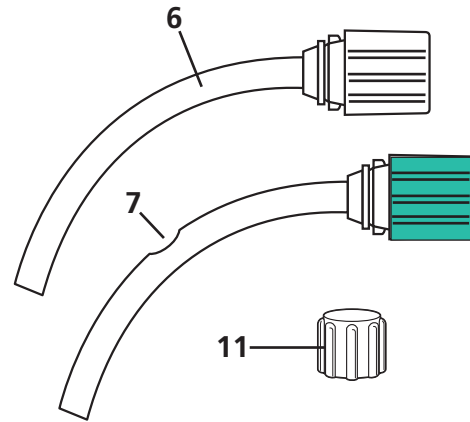
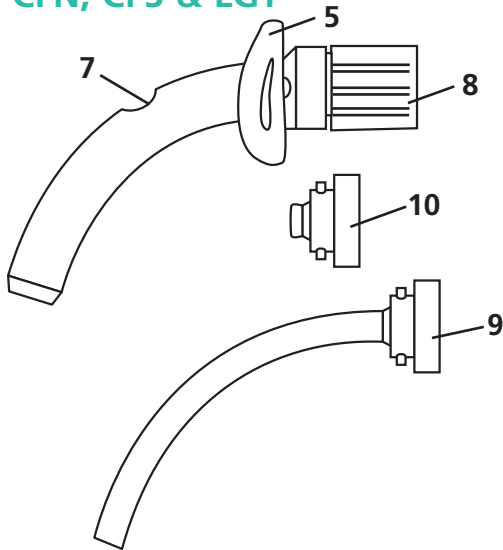

8. 15 mm Connector

Part of the inner cannula that sticks out at the neck. An artificial nose, ventilator tubing, manual resuscitation bag or Phonate™ Speaking Valve may be connected to this.

9. Low Profile Connector (CFN, CFS, LGT)

Designed so that it doesn't stick out and is less noticeable. It can not be attached to an artificial nose, ventilator hose or manual resuscitation bag.

10. Decannulation Plug (DCP)

For use with FEN and CFN. Attaches to the trach tube opening when the inner cannula has been removed

and cuff has been deflated.

Directs air through fenestration to your mouth and nose.

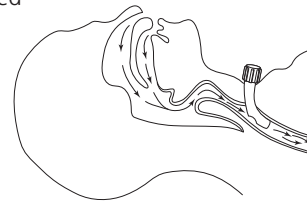

11. CAP

Fits over the green 15 mm connector on the fenestrated inner cannula of an FEN or CFN when the cuff has been deflated. Directs air through fenestration to your mouth and nose so you can speak.

Read Before Using Shiley® Tracheostomy Tubes

WARNING: The inner cannula with low profile connector is too short to attach to respiratory equipment such as ventilator tubing, an artificial nose, a manual resuscitation bag or a Phonate™ Speaking Valve. Use the cannula with 15 mm connector for this purpose.

CAUTION: The FEN and CFN are supplied with both a fenestrated and non-fenestrated inner cannula. Do not use the fenestrated inner cannula (green-colored connector) during mechanical ventilation.

WARNING: Shiley® Decannulation Plugs (DCP and DDCP) are designed for Shiley® Fenestrated Tubes only. They are not interchangeable with other manufacturer's products.

Product Descriptions

DCT, DFEN & PERC

1. Cuff

The "balloon" on the end of the trach tube. When inflated, it forms a seal against the wall of your windpipe. This stops the air flow through your mouth and nose so that you breathe through the trach tube.

2. Inflation Line

Thin plastic tubing that carries air to and from the cuff.

3. Pilot Balloon

Small plastic balloon-like component on the end of the inflation line. Indicates if air is in the cuff.

4. Luer Valve

Where the syringe is connected to inflate or deflate the cuff.

5. Soft Swivel Neck Flange

Contains product designation and size information. Twill ties or Shiley® Tracheostomy Tube Holders attach through the holes on either side securing the tube to your neck. Soft swivel design helps to position the tube properly and comfortably.

6. Disposable Inner Cannula (DIC)

The tube that fits inside your trach tube. Designed for single use only. Do not reuse or clean. Replace with a new one as directed by your doctor or home healthcare provider.

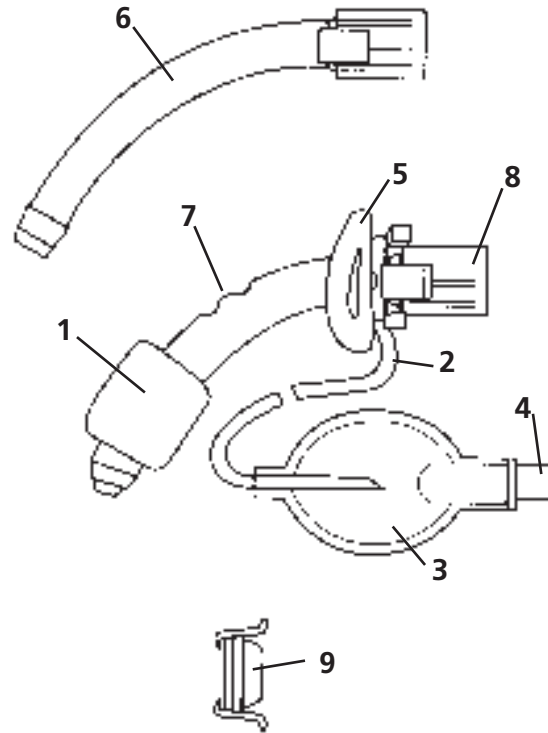

Product Descriptions

DCFN & DCFS

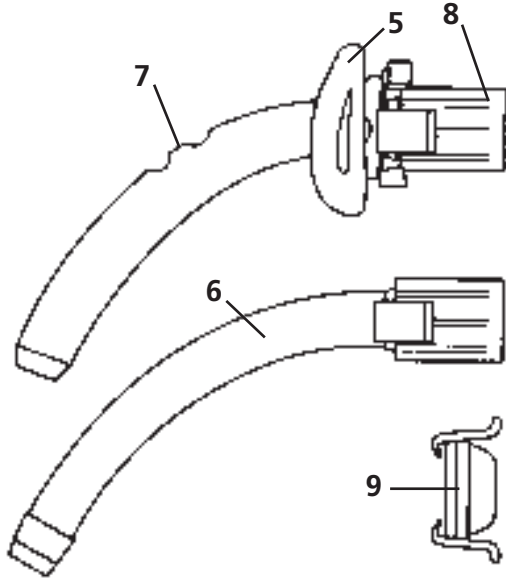

7. Fenestration (DFEN & DCFN)

A hole on the curved part of the trach tube. When the fenestrated outer cannula is used, the non-fenestrated inner cannula is removed, allowing air to flow through the vocal cords, mouth and nose so you can speak.

8. 15 mm Connector

Part of the inner cannula that sticks out at the neck. An artificial nose, ventilator tubing, manual resuscitation bag or Phonate™ Speaking Valve may be connected to this.

9. Disposable Decannulation Plug (DDCP)

For use with DFEN and DCFN. Attaches to the trach tube opening when the inner cannula has been removed and cuff has been deflated. Directs air through fenestration to your mouth and nose.

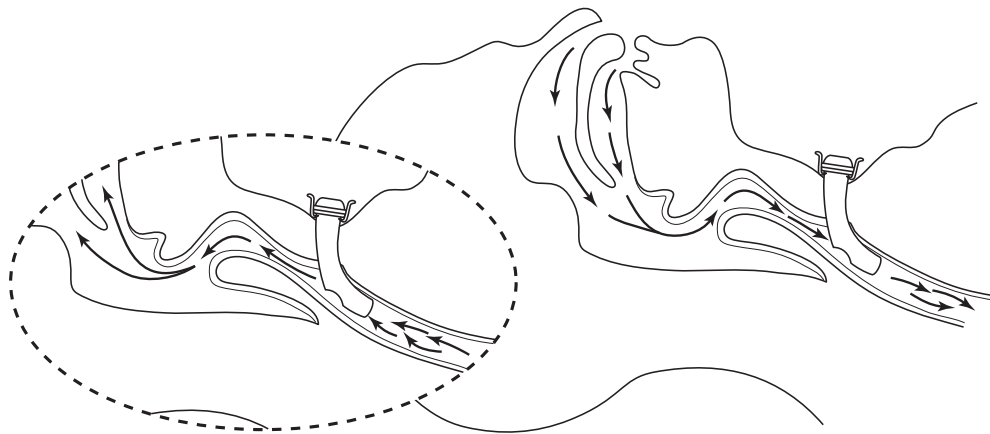

Read Before Using Shiley® Tracheostomy Tubes

WARNING: Shiley® Decannulation Plugs (DCP and DDCP) are designed for Shiley® Fenestrated Tubes only. They are not interchangeable with other manufacturer's products.

Product Descriptions

SCT

1. Cuff

The "balloon" on the end of the trach tube. When inflated, it forms a seal against the wall of your windpipe. This stops the air flow through your mouth and nose so that you breathe through the trach tube.

2. Inflation Line

Thin plastic tubing that carries air to and from the cuff.

3. Pilot Balloon

Small plastic balloon-like component on the end of the inflation line. Indicates if air is in the cuff.

4. Luer Valve

Where the syringe is connected to inflate or deflate the cuff.

5. 15 mm Connector

Permanent part of the trach tube that sticks out at the neck. An artificial nose, ventilator tubing, manual resuscitation bag or Phonate™ Speaking Valve may be connected to this.

6. Neck Flange

Contains product designation and size information. Twill ties or Shiley® Tracheostomy Tube Holders attach through the holes on either side securing the tube to your neck.

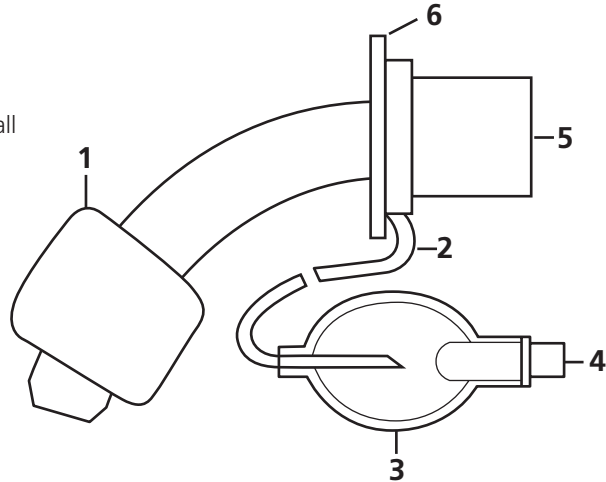

Speaking Valve

SHILEY® PHONATE™ SPEAKING VALVE (SSV/SSVO)

Description

The Shiley® Phonate™ Speaking Valve is designed to eliminate the need to use your finger to block the opening of your trach tube in order to talk. It is a one-way valve that attaches to the 15 mm connector of your trach tube, including pediatric sizes. It is available without an oxygen port (SSV) or with an oxygen port (SSVO).



airway obstruction, respiratory infection or heavy pulmonary mucous secretions.

How the Phonate™ Speaking Valve Works

When the Phonate™ Speaking Valve is attached to the 15 mm connector or hub of a fenestrated or cuffless tracheostomy tube, the valve opens when you breathe in, allowing air to enter your lungs. When you breathe out, the valve closes and causes air to go up your windpipe and through your vocal cords, allowing speech.



Contraindications:

The Phonate™ Speaking Valve is not for use with patients who have laryngeal stenosis, vocal cord paralysis, severe tracheal stenosis,

WARNING: Ensure that oxygen tubing does not excessively tug or pull at speaking valve attachment.

The Phonate™ Speaking Valve should only be used, on the order of a physician, with patients who are alert and cooperative.

The Phonate™ Speaking Valve should not be used while sleeping.

The Phonate™ Speaking Valve is not designed to be used with patients who are ventilator dependent.

Use the Phonate™ Speaking Valve only with a cuffless tube or a fenestrated cuffed tube. If a cuffed tube is used, the cuff must be completely deflated. Do not use with foam cuff tubes.

CAUTION: Do not attempt to remove the flexible diaphragm from the valve cap.

Use the Phonate™ Speaking Valve only after secretions have minimized following tracheostomy.

Pediatric patients should not use the Phonate™ Speaking Valve with oxygen port (SSVO) unless the port cap is not accessible to the patient.

NOTE: The Shiley® Phonate™ Speaking Valve should only be used on the order of a physician. Your home healthcare provider will decide if the Phonate™ Speaking Valve is right for you.

The Phonate™ Speaking Valve should be replaced after 30 days of normal use.

Replace the Phonate™ Speaking Valve should the flexible diaphragm become damaged, sticky or malfunction in any way.

How to Use the Phonate™ Speaking Valve

1. Wash hands thoroughly.
2. Carefully hold the trach tube with one hand while grasping the Phonate™ Speaking Valve with the opposite hand.
3. Attach valve to the 15 mm connector using a gentle twisting motion. (Remove the Phonate™ Speaking Valve if any respiratory distress or difficulty in breathing occurs.)
4. To remove the Phonate™ Speaking Valve, carefully hold the trach tube with one hand, while pulling the device from the trach tube with a gentle twisting motion.
5. If using the Phonate™ Speaking Valve for the first time, your home healthcare provider and/or speech pathologist will want to observe your breathing for a period of time to make sure you can breathe well around the trach tube and speak without difficulty.

Using the Phonate™ Speaking Valve with Oxygen Port (SSVO)

To provide supplemental oxygen when the oxygen port is present, remove the oxygen port cap, connect the oxygen line tubing and adjust the oxygen flow rate to prescribed setting.

NOTE: If oxygen port is blocked or obstructed, use a moistened Q-tip, with some of the cotton removed, or pipe cleaner to gently remove any remaining debris or encrustation. Rinse again and reexamine.

CAUTION: Do not use a brush for cleaning as it will cause damage to the valve.

Do not use hot water as it will damage the valve.

Do not use bleach or alcohol to clean the valve.

Do not ETO, autoclave or radiation sterilize the valve.

NOTE: The Phonate™ Speaking Valve is designed for single-patient use only.

Cleaning

The Phonate™ Speaking Valve should be cleaned daily while in use. If mucous or secretions become attached to the device, clean immediately.

1. Wash hands.
2. Remove the Phonate™ Speaking Valve by carefully holding the trach tube with one hand, while pulling the device from the trach tube with a gentle twisting motion.
3. Open the valve cap by pressing the cap lid away from the body at a position opposite the hinge.
4. If an oxygen port is present, do not apply excess pressure to the side of the port when opening the cap lid.
5. Prepare one of the following cleaning solutions:

- Cool or lukewarm saline
- Soapy water (a pure soap such as Ivory brand is recommended)
- Diluted household strength hydrogen peroxide (one part water and one part peroxide)
- Diluted household strength vinegar (one part water and one part vinegar)



6. Soak the opened valve in the cleaning solution for up to 15 minutes.
7. After the soaking period, agitate the valve in the cleaning solution.
8. Thoroughly rinse the valve in cool or lukewarm tap water to remove all cleaning solution.
9. Examine the valve for remaining debris or encrustations. Ensure that the flexible diaphragm is clean, not torn or sticky, and that it lies flat in the valve cap.
10. Check inside the valve to make sure it is smooth and undamaged. If you have an



oxygen port, use a pipe cleaner or Q-tip, with some of the cotton removed, or a pipe cleaner to clean inside the port.

11. Close the valve by firmly pressing the valve cap onto the main body until it snaps in place.

12. When not in use, store the Phonate™ Speaking Valve in a clean, dry place and protect from dust and moisture.

13. Always review usage and cleaning instructions with your home healthcare provider or speech pathologist before using the Phonate™ Speaking Valve.

Glossary (In Plain English)

Aerosol (*air-o-sol*) A device that puts moisture into the lungs.

Artificial Airway (*ar-teh-fish-all air-way*) Another word for tracheostomy tube.

Artificial Nose (*ar-teh-fish-all noz*) Also called HME (heat and moisture exchanger). A device that fits on your tube to warm and moisten the air you breathe.

Bacteria (*back-teh-ree-ah*) Germs.

CPR Cardiopulmonary Resuscitation
A method for getting someone to breath again once they have stopped.

Cannula (*can-you-la*)

Inner cannula Removable inner tube.

Outer cannula The outer part of the tracheostomy tube that is inserted into the trachea.

Cannulae (*can-you-lie*) More than one cannula.

Cuff The inflatable balloon on some tracheostomy tubes.

Distilled Water Water which is made by catching and cooling steam from boiling water. You can buy it at the grocery store.

Encrustation (*in-cruss-ta-shun*) Hard, crusty, dried mucus.

Home Healthcare Provider Nurses, nurse practitioners, doctors, respiratory therapists, speech pathologists or others that visit your home.

Home Healthcare Supplier The company where you get special medical equipment to use in your home.

Lumen (*loo-men*) Inside part of the tube, where the air goes in and out.

Mucus (*mu-kuss*) Slippery fluid that's produced in the lungs and windpipe. This sometimes dries and sticks to your tube.

Neck Flange The part of your tracheostomy tube where you attach twill ties or Shiley® Tracheostomy Tube Holders.

Obturator (*ob-tur-a-tor*) The semi-rigid stick you put into the tracheostomy tube to help guide it into the opening in your neck.

Phonation (*fo-nay-shun*) Talking or making sounds with your vocal cords.

Pliable (*ply-ah-bull*) Soft, flexible.

Saline (*say-leen*) Salt and water solution similar to water found in the body.

Secretions (*see-kree-shuns*) Another word for mucus.

Speaking Valve (*spee-king valv*) A one-way valve that lets air come in through the tracheostomy tube, but then sends it out past the vocal cords and mouth to make talking possible.

Speech Pathologist (*speech path-ol-o-gist*) A person trained to help people with speaking and swallowing problems.

Shiley® Phonate™ Speaking Valve



This compact valve fits on the end of your tracheostomy tube to help you speak more easily. Check with your doctor to see if you can use it. (For more information, see page 25.)

Shiley® Tracheostomy Tube Holder



This convenient alternative to twill tape comes in one size that fits pediatric to adult patients. Velcro®* fasteners easily attach to the tracheostomy tube neck flange. (Follow product instructions.) It is made of comfortable, latex-free foam-padded cotton.

Stoma (*sto-ma*) Hole in your neck where you insert the tracheostomy tube.

Sterile (*steer-ill*) Free from germs.

Suctioning (*suck-shun-ing*) Removing mucus in the tracheostomy tube.

Syringe (*seer-enj*) The plastic device the doctor uses to give shots, only there is no needle on it.

Trachea (*tray-key-ah*) Your wind pipe.

Tracheostomy (*tray-key-oss-tuh-mee*) The opening in your neck where your tracheostomy tube goes, to make breathing easier.

Tracheotomy (*tray-key-ot-o-mee*) An operation where the doctor makes an opening in your neck for a tracheostomy tube to make breathing easier.

Trach Tube (*trake toob*) Short for tracheostomy tube. This is the tube the doctor puts in the opening in your neck to help you breathe.

Ventilator (*vin-till-a-tor*) A machine that helps a person breathe.

Vocal Cords (*vo-cal cords*) Two strips of tissue in the voice box in the neck that vibrate to make sounds when you talk.

*Velcro is a registered trademark of Velcro U.S.A.

More Help

Internet References

The following web sites are provided for your convenience in locating information about tracheostomy care. Since patients' individual home care needs vary, please contact your doctor or home healthcare provider for guidance regarding any of the following references.

Tracheotomy

http://www.drugbase.co.za/data/med_info/tracheot.htm

Tracheostomy

<http://www.thriveonline.com/health/Library/surgery/surgery75.html>

Tracheostomy Surgical Description

<http://www.healthanswers.com/database/ami/converted/002955.html>

Tracheostomy On-Line Discussion Groups

<http://www.familyvillage.wisc.edu/lists/trachs.htm>

Various One-Way Speaking Valves: With Photos

<http://www.eskimo.com/~jlubin/disabled/vent/speakingvalves.htm>

Ventilator Dependent Links Section

<http://www.npg.com/npg/linksections/ventilator.dependent.htm>

Aaron's Tracheostomy Page

www.tracheostomy.com

Guillain-Barre Syndrome Foundation International

www.webmast.com/gbs/

Muscular Dystrophy Association of Canada

www.mdac.ca

Muscular Dystrophy Association

www.mdusa.org

National Health Information Center (NHIC)

nhic-nt.health.org

National Spinal Cord Injury Association

www.spinalcord.org

NPSIS National Parent to Parent Support and Information Service

www.nppsis.org

Parent-to-Parent Link Program

www.easterseals.org/programs.html

Parents Helping Parents, The Family Resource Center

www.php.com

Exceptional Parent Magazine
www.eparent.com

Speech, Language, and Hearing Center University of CO.
www.colorado.edu/slhs

Spinal Cord Injury Network
www.spinalcord.uab.edu/

World Institute on Disability
www.wid.org

American Academy of Otolaryngology
www.entnet.org/patient.html

Credits

Mallinckrodt gratefully acknowledges the contribution of the following individuals to the production of this home care guide.

Marie Lemoine MSN, RN, RCP
Paula Thompson BS, RRT
Rob St. John MSN, RN, RRT
Missy Toigo MA, CCC-SLP

NOTE: *Mallinckrodt Inc. has not reviewed all of the web sites listed above and makes no warranties or representations on the accuracy and/or any other aspect of the information contained in any of these sites or any other site. The information and procedures contained in the above listed references are those of the authors and institutions and do not necessarily reflect the opinions of Mallinckrodt Inc.*